

**PRASAR BHARTI (BCI)**  
**DIRECTORATE GENERAL: DOORDARSHAN**  
**DOORDARSHAN BHAVAN, COPERNICUS MARG,**  
**NEW DELHI – 110 001.**

No. 14(1)2010-11/ EI (P) TV.

Dated: 16 .09.2010

M/s \_\_\_\_\_  
\_\_\_\_\_  
\_\_\_\_\_  
\_\_\_\_\_

**Subject: Procurement of Flyway C-Band DSNG(1+1) System**

**Reference:** This Directorate Tender Enquiry No. 14(1)2010-11/EI (P) TV.

Dear Sir,

Please find enclosed herewith the revised Specifications No.SATD/1.8m\_400W\_Flyaway\_C\_DSNG\_AUG\_2010 dated 30.08.2010 for the Procurement of Flyway C-Band DSNG(1+1) System.

2. The aforesaid specifications are hereby authorized.
3. All bidders may read these specifications carefully.

All other terms & conditions of the tender will remain unchanged.



(T.P. Dimri)

(Assistant Engineer)

For Director General

Tele/ Fax +91- 11- 23387620

E-mail:- [ddpurchase401@yahoo.co.in](mailto:ddpurchase401@yahoo.co.in)

293

**PRASAR BHARATI  
(BROADCASTING CORPORATION OF INDIA)  
DIRECTORATE GENERAL: DOORDARSHAN**

**Spec: No: SATD/1.8m\_400W\_Flyaway\_C\_DSNG\_AUG\_2010**

**Dated: 30/08/2010**

**REVISED  
SPECIFICATIONS  
FOR  
Flyaway C Band DSNG (1+1) System**

*file*  
23/8/10

*[Signature]*

202

**PRASAR BHARATI**  
**(BROADCASTING CORPORATION OF INDIA)**  
**DIRECTORATE GENERAL: DOORDARSHAN**

**Spec: No: SATD/1.8m 400W Flyaway C DSNG AUG 2010**  
**Specification for Flyaway C-Band DSNG System**

This specification lays down the performance characteristics of C-band DSNG Flyaway system in 1+1 mode. The System comprises of encoder, modulator, C-band Block up converter, 400W TWTA (1:1) outdoor unit, 1.8 Mtr – 2 Mtr Fly away antenna with associated accessories like wave guides, Inter facility Links, Digital PLL LNBCs, 3 Port Feed, Dummy load, TLT and measuring equipment.

The specification mainly gives the representative requirements with MPEG-2 DVB-S2, 422P @ ML & MP@ML standards.

The scope for flyaway C-band DSNG system is detailed in specifications as given below:

S.No.	Item	Spec. No.	Page no.
1.	Introduction	SATD/Intro/2010	3-4
2.	Digital Video Compression System	SATD/Compression/2010	5-6
3.	Specification for upconverter	SATD/Upconverter/2010	7-9
4.	Specification for High Power amplifier	SATD/TWTA_400W/2010	10-11
5.	Specification for 1.8 to 2 Mtr PDA	SATD/PDA/2010	11-13
6.	Specification for LNBC	SATD/LNBC/2010	13
7.	Specification for IRD	SATD/IRD/2010	13-16
8.	Specification for TLT	SATD/Monitoring Eqpt./2010	16
9.	Physical, Environmental & Mech. Specs	SATD/Phys_Env_Mech/2010	17
10.	General Requirement	SATD/General Requirement/2010	18
11.	General Information	SATD/General/2010	19-20
12.	Equipment List	SATD/List_Eqpt/2010	21-23
13.	Block Schematic	SATD/DSNG/2010	24

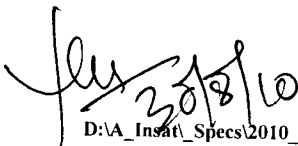

  
30/8/10

# 1 INTRODUCTION

The scope of this includes Supply of the complete flyaway C band DSNG system. This specification envisages providing a digital uplink facility in 1+1 configuration. The digital chain consists of Encoder, digital Modulator & Upconverter as a 1+1 system feeding to 400W Hermetically Sealed / Weather Proof HPA (1+1) and 1.8 Mtr to 2 Mtr PDA.

- I. A detailed block diagram showing the equipment layout and wiring should be given along with the offer for approval.
- II. The output of the HPA should be taken to an antenna of 1.8 Mtr to 2 Mtr through a flexible waveguide of suitable length. The antenna should be provided with a 3 port linear feed along with C band Digital ready LNBC, Two IRD & IFL (Interconnection Facility Links) etc. along with adjustments for azimuth, elevation and polarization. One down converter from C- band uplink frequency to L band is required for monitoring of uplink signal.
- III. The DSNG unit should also have input, output audio & video monitoring.
- IV. A Hand held Spectrum analyser (3GHz), which should be able to resolve the telemetry of INSAT series of satellite and other satellite on Indian sky in C band (down converted to L band). WFM (Digital) should be supplied with the unit.
- V. The system offered should contain all the accessories like compass, inclinometer, GPS receiver and necessary tools for integration / installation and maintenance.
- VI. The system should have a security scheme (addressing ability / encryption) (BISS Mode 1 and BISS-E (DSNG-CA) support), so as to eliminate open access to the transmitted service.
- VII. The full complement of the DSNG system should be packed in lightweight weather proof; shockproof containers (Hard cases) made of Carbon Fiber with Honey Comb Structure of thickness 15 mm Minimum of suitable size for airfreight, meeting the IATA accompanied baggage requirements to ensure reliable operation. Alternatively, front & back side opening Hard rack cases made of High Density Polyurethane, Alluminium alloy rack frame manufactured by Pelican or Hardigg or Thermodyne or equivalent can also be offered for equipment.
- VIII. The equipment boxes with shock absorber mounted sub frame should be made of lightweight alloy. Rubber gasket between sides of the case and sub frame should be provided. The front and back panel should be fully weather proof. One should be able to use the equipment without removing it from the boxes, after removing the front and back panels of boxes. The front of the equipment box should have translucent rain cover. All connectors should be of military type.
- IX. **The total weight of the complete system (in 1+1 configuration) including antenna along with the boxes but excluding Gen set and UPS should be kept as low as possible. The offer with the minimum overall system weight will be taken as the reference and the offers exceeding 30 kg above this reference will be rejected.**
- X. The supplier should give total number of boxes used for the complete system including size and weight of each box.
- XI. The equipment should be mounted in an ergonomical and orderly fashion. Easy access should be available to the PDP board.

*File*  
20/8/10

*SR*

201

- XII. The entire system designing should be able to withstand a rough handling during transportation, set -up, dismantling and packing.
- XIII. The system design should take care of operator safety as a prime consideration.
- XIV. The offer should include the supply of four sets of detailed technical manuals for operation, maintenance and servicing of all the equipment.
- XV. The specifications given are representative in nature and system will be selected on the basis of completeness.
- XVI. Technical compliance of each parameter including features with supporting documents should be given. Any offer with non compliance of this requirement may be summarily rejected
- XVII. The offer should include the maximum wind load at which the DSNG system will be stable and operate at the specified pointing stability.
- XVIII. A detailed acceptance test report procedure should be given with the offer.**
- XIX. Training should be given to Doordarshan Engineers in operation and maintenance of the system at each consignee's site.
- XX. Compliance should include antenna / system approval certificate from reputed international organisations.
- XXI. Tenderer will have to give demonstration of their product if required and asked for, by Doordarshan with in one month of the request.
- XXII. Tenderer can offer any option **either with BUC in HPA or BUC & HPA as separate units.**
- XXIII. **There should be a separate technical offer (separate BOM) for each combination of offered subsystems**
- XXIV. Encoder cum Modulator is also acceptable.
- XXV. All software should be perpetual

*file*  
30/8/10

*Dr*

## 2. Specification for Compression Equipment

### 2.1 SD Encoder

<b>SD Encoder_2.1.Design Standards</b>	
The system shall be designed to meet the international standards for digital broadcasting by satellite known as the MPEG-2 / DVB-S2 standards 422P @ ML & MP@ ML, selectable without any hardware changes. It should be possible to provide programme specific information, service name, language description and other related routine data. The system should have a security scheme (encryption) BISS Mode 1 and BISS-E, so as to eliminate open access to the transmitted service. <b>4:2:2 and 4:2:0 is required for SD MPEG-2 .</b>	
<b>2.1.2 Basic Configuration</b>	
The basic requirement is for a 1+1 system. Each system shall be complete and fully wired and installed in equipment cabinets to simplify the installation and commissioning process.	
<b>2.1.3 The Encoder should support following features: (as per EN 300 421 standards)</b>	
1. BISS Mode 1 and BISS-E	BISS Mode 1 and BISS-E
2. Low delay	For MPEG-2 - 200msec
<b>2.1.4 Video Inputs</b>	
The encoder shall be capable of accepting <b>SDI and embedded SDI inputs.</b>	
<b>2.1.5 Serial Digital Input Specifications</b>	
<b>Parameter</b>	<b>Specification</b>
(a) Serial Interface	SMPTE 272M, 270 Mb/s(10 bit) with embedded audio
(b) Format	ITU(R)-601
(c) Connector	BNC female,75 ohm
(d) Input Level	800 mV p-p nominal +/- 10%, SDI input
(e) Return Loss	better than 15 dB, 10 – 270 Mbps
<b>2.1.6 Video Compression Parameters</b>	
<b>Parameter</b>	<b>Specification</b>
(a) Video Resolutions (PAL)	720 x 576, 544 x 576,
(b) Profiles and Levels	422P @ ML and MP@ML
(c) Video Bit-rate	1 to 15 Mbps for 4:2:0 Profile. <b>4 to 25 Mbps for 4:2:2 Profile.</b>
(d) Temporal Processing	I, B, B, P frames structure to support low delay mode.
(e) Coding of Interlaced Video	Adaptive Field & Frame Processing support
(f) Spatial Redundancy	Discrete Cosine Transform (DCT) Reduction
(g) Chrominance Format	For MPEG-2 , 4:2:0 & 4:2:2 selectable,
(h) Aspect Ratio	4:3
<b>2.1.7 Audio Inputs</b>	

*File*  
30/8/10

*BR*

289

The encoder shall be capable of accepting AES/EBU or AES/EBU embedded digital inputs.	
<b>2.1.8 AES/EBU Digital Audio Input Specifications</b>	
<b>Parameter</b>	<b>Specification</b>
(a) Sample Rates	48.0 kilo samples/second
(b) Serial Interface	AES/EBU format
(c) Connector	XLR / with adapter for XLR
(e) Format, No. of Input	AES/EBU, 4 channels
<b>2.1.9 Embedded Serial Digital Audio Input Specifications</b>	
<b>Parameter</b>	<b>Specification</b>
(a) Serial Interface	SMPTE 272M, 270 Mb/s(10 bit) with embedded audio
(b) Format	AES/EBU, 4 channels
(c) Connector	BNC female
<b>2.1.10 Audio Compression Technique</b>	
<b>Parameter</b>	<b>Specification</b>
(a) Audio Encoding Method	<b>MPEG1 layer 2</b>
	MUSICAM MPEG audio coding standard layer 2
(b) Data rate	<b>64-256 kbps (MPEG-1, layer 2 Audio)</b>
<b>2.1.11 DATA INPUT ( OPTIONAL)</b>	
<b>2.1.12 Auxiliary Data Multiplexing</b>	
The encoder shall be capable of the transmission of broadcast data signals along with video and audio.	
<b>2.1.13 Asynchronous Serial Data Input Specifications (Optional)</b>	
<b>Parameter</b>	<b>Specification</b>
(a) Physical Interface (Connector)	<b>15 Pin D type or MPE (RJ45) connector</b>
(b) Electrical Interface	RS-232C or IP
(c) Data Rate	up to 38.4 kb/s, asynchronous
<b>2.1.14 Synchronous Serial Data Input Specifications (Optional)</b>	
<b>Parameter</b>	<b>Specification</b>
(a) Physical Interface (Connector)	15 pin subminiature 'D' type, male
(b) Electrical Interface	RS-422
(c) Data Rate	up to 2048 kb/s, synchronous

*Jlee*  
*30/8/10*  
*LC*

288

## 2.3 MODULATOR

2.3 DVB-S2 Satellite Modulator Specifications	
2.3.1 ASI Inputs	
Parameter	Specification
(a) No. of Inputs	2 nos.
(b) Compliance	<b>DVB-S (ETS 300421)</b> <b>DVB-S2 (ETS 302307) Should be capable of emitting signals using following modes:</b> <b>1. Backward compatible mode. (Should be capable of operating on both DVB-S &amp; DVB-S2 mode, one at a time)</b> <b>2. Constant Coding and Modulation (CCM).</b>
(c) Inputs bit-rate	upto 65 Mbps
(d) Byte stuffing modes	Byte & Signals Packet Burst modes.
(e) Connector	BNC
2.3.2 Forward Error Correction and Modulation Scheme	
Parameter	Specification
(a) FEC Coding(LDPC), RB & Convolution	DVB-S: 1/2, 2/3, 3/4, 4/6, 7/8, DVB-S2: 1/3,2/5,1/2,3/5,2/3,3/4,4/5,5/6,8/9,9/10 DVB-S2 8PSK: 3/5,2/3,3/4,4/5,5/6,8/9,9/10
(b) Spectrum Roll off factor	DVB-S: 25% and 35% selectable DVB-S2: 20%, 25% and 35% selectable
(c) Modulation Format	<b>DVB-S: QPSK</b> <b>DVB-S2: QPSK &amp; 8PSK</b>
(d) Transmission Rates	<b>(d1) Variable, 1.0 to 30 M symbols / sec (For stand alone Modulator)</b> <b>(d2) Variable, 1.0 to 15 M symbols / sec (For Combined Encoder and Modulator)</b>
(e) MPEG Format Support	Modulator should be able to modulate MPEG-2 streams of SD

### 2.3.3 IF Output Interface Specifications( In case of 70 Mhz Upconverter)

Parameter	Specification
(a) Output Frequency Range	52 to 78 MHz tunable
(b) Synthesizer Step Size	1 kHz, step
(c) Frequency Stability	<± 1Khz (all causes over 10 years)
(d) Output Impedance	75 ohms unbalanced
(e) Connector	BNC, female
(f) Output Return Loss	>20 dB (50 – 90 MHz)
(g) Output Level Range	-20 to 0 dBm
(h) Level Step Size	0.1 dB, steps
(i) Spurious Outputs	<-65 dBc/4KHz@-10dBm
(j) Synthesizer Phase Noise	Meets requirements of IESS-308
(k) CW mode	Selectable
(l) Noise floor (C/ No)	< -120 dBc/Hz
(m) Spectrum sense	Normal/Inverted

OR

file  
30/8/10  
R

257

**2.3.4 L-Band Output Option (In case of L band BUC)**

S.No.	Parameters	Specification
1.	Frequency	950 to 1500 MHz, step size 125 KHz
2.	Return loss	> 10 dB
3.	Compliance	EN 302307
4.	Output Connector	SMA(F)
5.	L band output impedance	50 ohm
6.	output level	- 20 to + 5dBm
7.	1 dB compression output	+10 dBm
8.	Output Gain	0 to +5 dBm
9.	Output Gain step size	0.1 dB
10.	Phase Noise 10 Hz	< -30dBc/Hz
	100 Hz	< -60dBc/Hz
	1 KHz	< -70dBc/Hz
	10 KHz	< -80dBc/Hz
	100 KHz	< -90dBc/Hz
11	Spurious	<-60 dBm, and <-55 dBc/4KHz

SATD/Upconverter/2010

**3. SPECIFICATION FOR UP CONVERTERS**

**3.1 C band Up-converter (in case of 70 MHz Modulator as per specification at Sl. No. 2.3.3)**

1.	Input Frequency	:	70 ± 18 MHz
2.	Output B/W	:	+/- 18 MHz
3.	Frequency Steps Size	:	Synthesized 125 KHz
4.	Input Power	:	-20 dBm nominal
5.	Output Frequency range	:	5.85 to 6.425 GHz GHz
6.	Frequency Accuracy	:	+/- 200 Hz
7.	Frequency Stability	:	+/- 1000 Hz from 0 to 50 Deg. C
8.	Output Power	:	15 dBm
9.	Gain Adjustment	:	25 dB
10.	Phase Noise		
	10 KHz	:	-80 dBc per Hz
	100 KHz	:	-90 dBc per Hz
	1 MHz	:	-110 dBc per Hz
11.	Spurious	:	-65 dBc modulated < -70 dBm unmodulated (Non carrier related)

OR

*file*  
*30/10*

*LR*

3.2 Block Upconverter ( In case of L band Modulator as per specification at Sl. No. 2.3.4)

S.No.	Parameter	Specification
1	Type	Single conversion
2	Output Frequency	5.85 to 6.425 GHz
3	Input Frequency	950 to 1500 MHz
4	Impedance	50 ohms
5	VSWR	1.5:1 maximum
6	Non-damage	+15 dBm minmum
7	<b>External reference characteristics</b>	
a	Location	Input center conductor or reference connector
b	Frequency	10 MHz
c	Level	-5 to + 5 dBm
8	<b>Output characteristics</b>	
a	Impedance	50 ohms
b	VSWR	1.3:1 maximum
c	Power output (1 dB compression)	+10 dBm minmum
d	Power Attenuator	0 to 20 dB in 1 dB step size
9	<b>Transfer characteristics</b>	
a	Noise figure	15 dB typical (with minimum attenuation)
b	Gain	26 ± 1 dB at 23 degree C
c	Gain flatness	±0.2 dB/any 40 MHz, ±0.25 dB/any 80 MHz, ±0.5dB/RF-band
10	<b>Gain stability</b>	
a	Constant temperature	±0.25 dB/24 hours
b	Attenuation control	32 dB / 0.1 dB step remote control or 0 to 10 volts DC
11	<b>Group delay</b>	
a	Slope (any 80 MHz segment)	0.0125 ns/MHz
b	Parabolic (any 80 MHz segment)	0.000625 ns/MHz <sup>2</sup>
c	Ripple (any 80 MHz segment)	0.5 ns
d	Total	1 ns peak-to-peak over RF-band
12	<b>Spurious output</b>	
a	Signal related	65 dBc minimum
b	IF signal second harmonic	-55 dBc maximum at 0 dBm output power
c	Signal independent (in band)	-100 dBm maximum
d	Signal independent (out-of-band)	-70 dBm maximum
e	Image rejection	-60 dB minimum
f	Second harmonic output (P1 dB)	-40 dBc maximum
g	Intermodulation distortion	With two in band output signals at 0 dBm, third order intermodulation products are less than 46 dBc
13	Mute	60 dB minimum

*Handwritten signature and date:*  
 30/8/10

285

4. **SPECIFICATION FOR LINEARISED HIGH POWER AMPLIFIER**

The high power amplifier is to be used for the final power amplification of the digital RF signal in C band, to be fed to the antenna after proper processing through filters etc. The following will give a standard specification of the amplifier Amplification has to be carried out in two stages i.e SSIPA and TWTA.

- 4.1 Type : Outdoor type 400 Watt TWT
- 4.2 Frequency : 5.85 to 6.425 GHz,
- 4.3 Output Power : at flange 350 Watt (Min.)
- 4.4 Gain at rated power : 43 dB minimum  
73 dB minimum (with SSIPA)
- 4.5 Gain Variation
- 4.5.1 Narrow Band : 1 dB max. over any 40 MHz
- 4.5.2 Full Band : 3 dB max.
- 4.6 Gain Slope : +/- 0.04 dB per MHz (Max.)
- 4.7 Gain Stability : +/- 0.25dB (Max.) over 24 hrs.  
+/- 1.0 db max. over operating temp. range at any frequency.
- 4.8 Inter Modulation : With linearizer: -24 dBc or better with two equal carriers at 4 dB output back off.  
Without Linearizer: -18 dBc or better with two equal carriers at 4 dB output back off.
- 4.9 Second Harmonic Output : -60 dBc
- 4.10 Group Delay
  - (a) Linear : 0.01 nSec. Per MHz across any 40 MHz
  - (b) Parabolic : 0.005 ns /MHz<sup>2</sup> over any 40 MHz band
  - (c) Ripple : 0.5 ns p-p over any 40 MHz band
- 4.11 VSWR : input 1.3: 1(max.)  
Output 1.3:1 (max.)
- 4.12 Power Supply : 180to 245 V AC, Single Phase
- 4.12.1 Frequency : 47 to 53 Hz
- 4.13 Power factor : 0.95 (Min.)
- 4.14 Spurious (Max.)
  - Receive Band (3.7 to 4.2GHz) : -120 dBW / 4 KHz
  - Transmit Band (5.85 to 6.2 GHz) : -65 dBW / 4 KHz

*file*  
30/8/10

*[Signature]*

4.15	Controls	:	HV on, Fault reset, heater standby
4.16	Power Consumption	:	less than 1500 watts.
4.17	Monitoring Digital	:	HV on, Heater timeout, standby, summary fault, Helix current/ Arc fault, Helix current latched fault, Over voltage fault, Temp fault, Fan lock
4.18	Monitor Analog	:	Helix current, TWT Temp. RF output
4.19	Altitude	:	3000 Meter AMSL
4.20	Shock vibration	:	Air transportation and Mechanized material handling e.g. Fork lifts
4.21	Cooling	:	Forced Air

284

SATD/PDA/2010

**5. Specification for 1.8 Mtr –2 Mtr Uplink Antenna.**

**INTRODUCTION**

This antenna would be used to uplink TV signals & it is required for uplinking digital channels through 400W TWTA, hence the feed handling capacity should be as given in the specifications below.

1. It should have at least **1 Uplink port and 2 downlink ports** (i.e. both for Vertical & Horizontal Pol.)
2. Antenna should be made of lightweight **carbon composite fiber with Honey Comb Structure of thickness 20 mm Minimum**
3. The antenna should conform to latest CCIR recommendations, ITU-R Rec. 580- 5, satisfying the  $29 - 25 \log(\theta)$ .
4. Technical offer should include **antenna system type approval certificate or antenna performance verification report from reputed International organisations or satellite operators like NOCC or INTELSAT or EUTELSAT or NSS etc.**

**5.1 ANTENNA SPECIFICATION FOR THE C BAND ANTENNA .**

1. Size : 1.8 Mtr to 2 Mtr ( nominal circular equivalent)
2. Mount : Elevation – Azimuth ( Manual)
3. Frequency of operation
  - Transmit : 5.85 GHz to 6.425 GHz.
  - Receive : 3.7 GHz to 4.2 GHz
4. Gain :
  - Transmit : 39.0 dB (Min.) for 1.8 Mtr / 41.0 dB (Min) for 2 Mtr @6 GHz
  - Receive : 34.0 dB (Min.) for 1.8 Mtr/ 36 dB (Min) for 2 Mtr @ 4 GHz
5. Off-axis gain
  - Transmit :  $29-25 \text{ Log}\theta$ ,  $(100 \lambda/D)$  Deg $\theta$ <20 Deg. & -3.5 dBi 20 Deg $\theta$ <26.3 Deg
6. Polarisation Type : Linear Orthogonal,

*Handwritten signature and date: 30/8/10*

- 7. Polarisation Adjustment : +/-90 Deg. fine (Calibrated graduation, absolute)
- 8. Azimuth Adjustment : +/-180Deg. (including +5<sup>0</sup> fine adjustment) (Calibrated graduation, relative)
- 9. Elevation Adjust : 10 Deg to 80 Deg. (including +5<sup>0</sup> fine adjustment) (Calibrated graduation, absolute)
- 10. Cross Polar Isolation : 30 dB relative to co-polar gain within 1 dB  
**Contour (Factory test report to be submitted at the time of inspection along with spectrum plots)**
- 11. VSWR
  - Transmit : 1.3: 1
  - Receive : 1.3: 1
- 12. Port to port isolation
  - Transmit to receive : 40 dB (100 db with TRF)
  - Receive to transmit : 30 dB
- 13. Wind Speed
  - Operational : 60 KMPH
  - Survival : 100 KMPH.(in deployed condition)
- 14. Pointing Stability : <+ / - 0.2 deg.
- 15. Wave guide Flanges : Tx CPR137 and Rx CPR 229

SATD/LNBC/2010

**6. SPECIFICATION FOR LNBC (DIGITAL PLL C BAND)**

These LNBCs are to be used for the reception of digital video/audio signals through the satellite:

- 1. Input frequency range : 3.7 GHz to 4.2 GHz
- 2. Local Oscillator frequency : 5.150GHz
- 3. L.O. Stability : ± 10 PPM
- 4. L.O. Phase noise : Better than 70 dBc/Hz @ 1KHz  
Better than 80 dBc/Hz @ 10KHz  
Better than 90 dBc/Hz @ 100KHz
- 5. Output frequency : 950 MHz to 1450 MHz
- 6. Conversion gain : 55 dB
- 7. Gain response : Better than ± 1 dB/40 MHz
- 8. Output level at 1dB compression point : 6 dBm
- 9. Output Connector : F connector
- 10. Input VSWR/Output VSWR : Better than 2.5:1
- 11. Noise Temp. : Better than 30 deg K
- 12. Power supply requirement : Should work between + 15V to +24V with current consumption of about 350 mA
- 13. Input flange : CPR229

*[Handwritten signature]*  
*[Handwritten signature]*  
 30/8/10



286 \

7.3 Transport Stream O/P MPEG-2 DVB-ASI on BNC

7.4 Video Output Specifications

- a) The IRD shall have one composite video output, Two SD-SDI output
- b) There should be a genlock input to synchronize the IRD with external reference video signal. (Firm has to demonstrate during the demo, as and when asked as part of technical evaluation of Tender.)

7.4.1.1 Analog Video Output Specifications

Parameter	Specification
(a) Connector Type	BNC (75 Ohms)
(b) Quantity	1 Nos. of analog composite PAL-B CCIR Standard
(c) Level	1.0 V p-p +/- 5%

7.4.1.2 Digital Video Output Specifications (SD-SDI)

Parameter	Specification
(a) Serial Interface	SMPTE 272M, 270 Mbit/s (10bit),
(b) Connector Type	BNC (75 Ohms)
(c) Quantity	1 Nos. of DIGITAL
(d) Level	800mV p-p for SDI As per ITU-R



Note: ASI to SDI decompression should take place directly, i.e. not through Analog to Digital converter.

7.4.2 Video Performance Specifications

Parameter	Specification
(a) Frequency Response	with in 2 dB at 5 MHz
(c) Chroma-Luma Delay	±30 ns, maximum
(d)Field Time Distortion	< 2%
(e) Line Time Distortion	< 1%
(f) Short Time distortion	< 2%
(g) Differential Gain	< 4%
(h) Differential Phase	< 2°
(i) Signal to Noise Ratio	>55 dB (luminance weighted)

7.4.3 VBI Signal Reinsertion Specifications

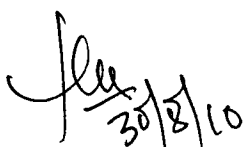
Parameter	Specification
(a) VBI Formats Supported	WST VITC
(b) Range of VBI Lines	Field 1 lines 7 to 22 (PAL) and corresponding lines of Field 2
© Synchronization with video	With in ± 1 frame
(d) Preservation of line numbering	VBI data shall be reinserted on the Original line number

## 7.5 Audio Output

780

### 7.5.1 Analog Audio

Each analog audio output shall be presented as a stereo pair. In the event of "Mono" transmissions, the same encoder input channel will be output to both left and right connectors. In other modes ("Stereo", "Joint Stereo" and "Dual Mono"), the two encoder input channels will be output as left and right.

Means shall be provided to combine the left and right channels on the IRD output to produce a mono output from stereo transmissions to accommodate those sites not equipped for stereo transmission.

#### 7.5.1.1 Analog Audio Output Specifications

Parameter	Specification
(a) Output Impedance	600Ω (balanced)
(b) Number of Outputs	4, configurable as Stereo, Joint Stereo, Single mono, Dual mono.
(c) Connector Type	XLR Male Socket or with suitable XLR Adapter

#### 7.5.2 Digital Audio Output Specifications

Parameter	Specification
(a) Output Level	2 to 7 volts
(b) Output Format	AES/EBU
(c) Load Impedance	110 Ohms
(d) Connector Type	XLR male Socket or with suitable XLR adapter (i.e. no terminal block)
(b) Number of Outputs	2, Stereo Channels

#### 7.5.2.1 Audio Performance Specifications

Parameter	Specification
(a) Peak Output Level	+ 18 dBm into 600Ω balanced
(b) Clipping Level	S/W Selectable to be provided or any preset value between +18 dBu to +25 dBu
(c) Sampling Rates	48 KHz
(d) Frequency Response	40 Hz to 20 kHz ± 2 dB
(e) THD	<0.3 % at 1 kHz
(f) Dynamic range	80 dB (ITU-R/Arm weighting)
(g) Cross talk at 1 kHz	60 dB, full scale (20 Hz to 20 kHz)
(i) Signal to noise ratio	55 dB (min) at 0 dBm

## 7.6 LNB Power Supply & Control

(a) LNB Voltage	+ 13 V (Vertical)/ 18 V (Horz) polarizations switching or 19 V fixed.
(b) Power Consumption	400 mA. (Max.)
(c) Over Current protection	Fold back current limiting.
(d) LNB Power Supply & Control	Receive Polarization Control by electrical Command Via LNB-IF feeder (High & Low band switching Pulse for KU-Band operation).

*file*  
30/8/10 *R*

279

**7.7 Size**

Mount 19" Rack Mount

(Firm has to demonstrate the features of IRD during the demo, as and when asked as part of technical evaluation of Tender).

SATD/Monitoring Eqpt. /2009

**7.9 Audio/ Video monitoring with 5" to 6" TFT monitors**

To monitor the audio and video quality multiple Monitor with corresponding Audio Bar Graph panels are required.

**7.9.1 Specifications for Monitors**

- 1. Display (Viewing Area) 5" or more
- 2. Resolution (Pixels) 480H x 234V ( min)
- 3. Dot Pitch 0.35 mm x 0.35 mm ( max)
- 4. Brightness Better than 250cd/m<sup>2</sup>
- 5. Aspect ratio 4: 3
- 6. Composite Video I/P per monitor One
- 7. Video Input **SDI Embedded and Analog**
- 8. Viewing Angle 140 Degree (H), 120 Degree (V)

**7.9.2 Specifications for Dual Stereo Bar-Graph (Two Stereo Audio per channel)**

- 1. Input Source Type **AES/ EBU and Analog**
- 2. Frequency Response 100 Hz to 15 kHz  $\pm$  0.5dB
- 3. Level Meter stereo channel viewing >25 Segment level display, High resolu
- 4. Standard Scale -30 to +15dB

**8. Specification for Test Loop Translator (TLT) from C-band U/L frquency to L-band**

Test Loop Translator (C-band uplink frequency to L-band) is to be used to check the monitoring output of Upconverters & HPAs. Monitoring ports of Upconverter and HPAs will be fed to TLT . Output of TLT will be fed to IRD through L-band input. The specifications are detailed below:

1. Input Frequency	5.85 GHz to 6.425 GHz
2. Output Frequency range	950 MHz to 1450 MHz
3. Input return loss	18 db minimum
4. Out put return loss	18 db minimum
5. Phase Noise	IESS308/309 compliant

*Handwritten signature*

*Handwritten signature and date: 30/8/10*

## 9. Physical, Environmental & Mechanical Specifications

### 9.1 Power Supply

All Equipments shall operate from a wide range of power supply voltages without interruption or damage.

Parameter	Specification
(a) Voltage Range	180 to 245 VAC
(b) Frequency	47-53 Hz

### 9.2 Environmental Specifications

#### Indoor Type of Equipment

Parameter	Specification
(a) Operating Temperature	0°C to 45°C
(b) Storage Temperature	-20°C to 75°C
(c) Humidity	0 to 95% non-condensing
(d) Altitude	0 to 3000 m

#### Outdoor

Parameter	Specification
(a) Operating Temperature	-20°C to 55°C
(b) Storage Temperature	-20°C to 75°C
(c) Humidity	0 to 100% non-condensing
(d) Altitude	0 to 3000 m

### 9.3 Mechanical Specifications

Parameter	Specification
(a) Construction	Modular, equipment boxes with shock absorbers. The front and back panel should have fully enclosed weather proofing panel. The equipments can be used without removing from the boxes, after removing the front and back panels of box
(b) Cooling	Internal circulation fans

file  
30/8/10

SR

**10. General Requirement**

1. Supplier should give a certificate from OEM for providing spares and maintenance support for this system for the next seven years.
2. All the essential items which the manufacturer feels are necessary to complete the equipment/chain for the full exploitation of all the features of the equipment offered, may also be quoted.
3. Equipment from renowned and well-known firms of the industry with proven track record only will be accepted. The tenderer should enclose a list of organizations to which same equipment as is in this tender has been supplied.
4. The system/equipment should be mounted in industry standard boxes.
5. Cost of all the equipment and items which are necessary to complete the configuration to meet the specifications/requirement should be very clearly specified and will be included for commercial evaluation.
6. The system offered should be complete in all respect even if missed in the specification.
7. **Tender without the consent / counter signature of OEM representative in respect of compliance statement and associated part of Bill of Material (corresponding to respective sub systems including OEM items and associated third party items) will be treated as in complete proposal and will be summarily rejected without any reference of it to the firm.**
8. If required, one sample of complete system in all respects or sub system along with operation & technical manuals would be made available for technical evaluation.
9. **The firm should have supplied installed and successfully commissioned Earth stations for TV uplink/ DSNG in India or abroad and should have been in the field for at least 3 years. Proof of supply of DSNG to be enclosed with Tender.**

**10a. DOCUMENTATION**

**Offer should include the supply of four complete (including manuals for options, if any) set of documents (in original) of operation and maintenance (i.e. two with the equipment with each unit, one additional set for Design Directorate and one each for respective Zonal offices). All the documents should also be supplied in CDROM with each set of document. The CDROMs supplied should have full features of find & search of Microsoft. Cost if any may be included in the offer. One set of the above manuals for each equipment should be enclosed along with the tender for technical evaluation. Offers without the manuals for evaluation are liable to be rejected.**

**10b. GUARANTEE**

- i) The equipment shall be guaranteed against any manufacturing defects for a period of **two year from the date of supply.**
- ii) Any parts failing during the guarantee period shall be repaired/replaced free of charge by the supplier at site i.e. no transportation charges would be paid by DD for transporting the defective / repaired items if required to be removed from site during the guarantee period.
- iii) Guarantee period is to be extended corresponding to the outage period if the failure rectification takes more than 15 days time.

*Handwritten signature and date: 30/8/10*

*Handwritten signature*

**11. GENERAL INFORMATION**

1. A point-by-point compliance statement **from the principal manufacturer in respect of all the points, sub-points and paras laid down in this specification from page 1 onwards** is to be enclosed along with the offer. Mere signature on a copy of our specification shall not be accepted as a compliance statement. **Page no. of location of data sheet should be given in page no. column. One copy of compliance statement and Bill of material (in MS Excel format) should also be given on CD-ROM.**

(a) Compliance statement in the format as indicated below only shall be accepted.

Sr. No. of DD specs.	DD specs.	Compliance (Yes/No)	Performance fig. of equipment offered.	Deviations, in case of non-compliance	Optional items if any required to make the system Compliant to DD specs.	Features in the system offered Which exceed DD specs.	Page No.	Remarks
1	Introduction							
2	Specifications							
3	Essential features (a)----- (b)-----							

- (b) The manufacturer should also record the performance figures of the equipment offered in the quote for which the compliance statement is enclosed.
- (c) The compliance statement should be supported by highlighted record of these in the technical literature/data sheets enclosed with the tender **and a clear reference to the attached supporting document should be given in the remarks column against each & every specs.** Any offer without proper supporting document of each & every specs and containing only a commercial hand out/pamphlet will be rejected. In case the parameters given in the data sheet / technical literature is different from the one mentioned anywhere else or in the compliance statement of the offer, the one mentioned in the data sheet / technical literature will be considered to be authentic.
- (c) Any deviation from the specifications detailed in the compliance statement is to be highlighted separately.
- (d) Offers without the proper & duly completed compliance statement are likely to be rejected with the sole responsibility of tenderer and no further claim/correspondence will be entertained.

**2. Ordering Information**

One soft copy of ordering information / Bill of material, in **MS Excel format**, should be provided along with the quote. The sequence of item should be kept same as tabulated in the equipment list of DD Specification.

File  
30/8/10  
Sv

275-

**3. SPARES**

1. A complete **recommended spare list** with price quote should be offered, along with the bid.
2. The cost of spares shall not be taken into account for deciding lowest tenderer.
3. The bidder should enclose a certificate from OEM for providing spares and maintenance support for offered system for next five years, starting after expiry of two years of warranty period.

**4. ACCESSORIES**

1. All essential accessories like cables, connectors and power cord etc. should be included in the offer. Optional accessories should be quoted separately.

**5 INSPECTION**

1. All the equipment to be supplied against the supply order for this tender shall be subjected to inspection at New Delhi / manufactures facility by Doordarshan.
2. ATP is to be provided by the Tenderer for approval by Doordarshan before inspection.

*[Handwritten signature]*

*[Handwritten signature]*  
30/8/16

**12. EQUIPMENT LIST**

The quantities indicated are provisional. Bidder should quote for quantities as required to complete the system.

Sr. No.	DESCRIPTION	QTY per Unit	MAKE	MODEL
1	<b>FLYAWAY 1.8 Mtr to 2 Mtr Antenna System</b>	<b>1Set</b>		
	a Lightweight 1.8 / 2 meter segmented antenna and 3 axis mount system	1		
	b C band 3 port feed (Tx range 5.7 to 6.2GHz)*	1		
	c Diplexer for 3 port operation	1		
	d Transmit reject filter (With > 80 db isolation)	1		
	e Cross axis waveguide kit	1		
	f Interconnecting cables	1 set		
	g System tools	1		
	h Compass	1		
	i Inclinometer	1		
	j Hand held GPS receiver (Equivalent to Garmin)	1		
	k. Antenna flight case ( <b>Hard case –Carbon Fiber or Pelican or Hardigg or Thermodyne or equivalent</b> )	1 set		
	L NOCC Clearance of above Antenna System	1 set		
m Essential Additional Item (if any) to Complete the antenna System * (Factory test report for cross pole isolation to be submitted at the time of inspection along with spectrum plots)				
2	<b>HIGH POWER AMPLIFIER</b>	<b>1Set</b>		
	a 400 watt (350watt flange) C band TWT amplifier (outdoor unit)	2		
	b Lineariser for 400 watt C band TWT amplifier	2		
	c Amplifier Redundancy controller	1		
	d. Wave guide Switch for 1+1 redundancy & Dummy load.	1		
	e. RF Equipment case ( <b>Hard case –Carbon Fiber or Pelican or Hardigg or Thermodyne or equivalent</b> )	1		
	f. Essential Additional Item (if any) to Complete the HPA System	1 set		
3	a <b>Upconveter</b>	2		
	b Up converter Redundancy Switch (controller)	1		
	c Essential additional items (if any) for Up converter system	1set		
	d Hard case for transportation	1 set		
4	<b>Digital Equipment</b>			
	a Encoder (for SD MPEG-2)	2		
	b BISS-E scrambling (H/W & S/W) for Encoders	2		
	c 4:2:2 option for encoder	2		
	d Modulator #	2		
	c Digital Equipment Case ( <b>Hard case –Carbon Fiber or Pelican or Hardigg or Thermodyne or equivalent</b> )	1 set		
d Essential additional items (if any) for Encoder& Modulator	1 set			

*File*  
*30/8/10* *SV*

273

	# Tenderer can also quote encoder cum modulator			
<b>5</b>	<b>Receiving Setup equipment</b>	<b>1 Set</b>		
a	IRD (Integrated Receiver Decoder) for MPEG-2 (4:2:0 and 4:2:2 ) with BISS-E De-scrambling Facility and SDI output	2		
b	LNBC (3.625 GHz to 4.2 GHz)	2		
c	Essential additional item (if any) to complete the receive set up	1 set		
<b>6</b>	<b>Monitoring Set up consisting of</b>			
a	C-band Uplink frequency to L Band Down Converter (TLT)	1		
b	DUAL Picture TFT monitor with size 5" to 6" (which can fit in the 19" rack) with SD SDI, AES/EBU inputs)	1		
c	Dual AES and Dual Analogue Audio Monitor with bar graph & Speakers (which can be fit in the 19" rack below the TFT monitor) (Two stereo Audio per video)	1		
d	Waveform Monitor Hand held for SD-SDI input (similar to WFM 4000 or equivalent)	1		
e.	Analogue to SD SDI converter and equalizer (up to 200 meter length) (MIRANDA, KRAMER, GVG, or equivalent.)	2		
f.	SD SDI / (AES/EBU) input matrix switcher 4X4 (for Video with associated Audio) (LEITCH, NETWORK, Probel, Kramer or equivalent)	1		
g.	SD SDI Colour bar and tone generator (Tektronix, KRAMER , R&S or equivalent)	1		
h.	Audio (analogue and Digital) Embedder (similar to Miranda, Crystalvision, Snell & Wilcox, Ensemble etc.) (2 AES/ EBU channels per card)	2		
i	Analog Video to SD SDI Converter	3		
<b>7</b>	<b>Measuring Equipment</b>			
a	Handheld Spectrum Analyzer (100KHz to 3GHz with standard Accessories), which should be able to resolve the Telemetry of INSAT series of satellite in C-band (Down converted to L band.) (Noise floor should be better than -105 dB at 1khz RBW) (With LCD Display)	1		
b	Hand held Satellite tracker for DVB-S2 (equivalent to Horizon Global, Prodig)	1		
c	Hard case for transportation	1 set		
<b>8</b>	<b>Maintenance Tool Kit</b>	<b>1 Set</b>		
a	Set of Tools for maintenance including soldering station (similar to Weller make)	1set		
b	Flexible wave guide with flange (1 meters each ) (Additional)	5		
c	Tool box ( <b>Hard case type</b> )	1		
d	Essential Additional items (if any) for maintenance work	1set		
e	Hard case- Carbon Fiber or Pelican or Hardigg or Thermodyne or equivalent, for transportation of Audio-Video cables as per IATA regulation	1		
<b>9</b>				
a	UPS of 5.0 KVA (Min) with 15 Min backup	1		
b	Essential additional item (if any) to complete the UPS system	1 set		
e	Hard case - Carbon Fiber or Pelican or Hardigg or Thermodyne or	1 set		

Handwritten signature and date: 20/8/10

272

		equivalent for transportation			
10	a	System Integration & System Engineering	1set		
11		<b>Manuals &amp; CDs (for S/w) of all The Equipments offered</b>			
	a	CD ROM for all the software required in the System	1set		
	b	System Manuals (Operation and Maintenance/ Service Manuals)	1set		
	c	<b>Software upgrades within two year of installation should be supplied free of cost.</b>			
12		<b>Training</b>			
	a	Training for Doordarshan Engineers in India at each consignee's site	1 job		
13		Any other item to Complete the Specification, Installation and commissioning of the system.			

**Note 1: All software backups should be supplied on CDs. Software upgrades within three year of installation should be supplied free of cost. Doordarshan should be registered as a ultimate user with perpetual validity at the time of purchase of all software licenses.**

**Note 2: Tender without the consent / counter signature of OEM representative in respect of compliance statement and associated part of Bill of Material (corresponding to respective sub systems including OEM items and associated third party items) will be treated as in complete proposal and will be summarily rejected without any reference of it to the firm.**

1. Any incomplete proposal is liable to be rejected.
2. The prices for Software & Hardware wherever required should be given along with the equipment.
3. All the relevant options of all the equipments to utilize the equipments to its full capacity must be quoted.
4. **There should be a separate technical offer (separate BOM) for each combination of offered subsystems**

*File*  
30/8/10 *SR*

271

### BLOCK SCHEMATIC DIAGRAM OF C BAND DSNG

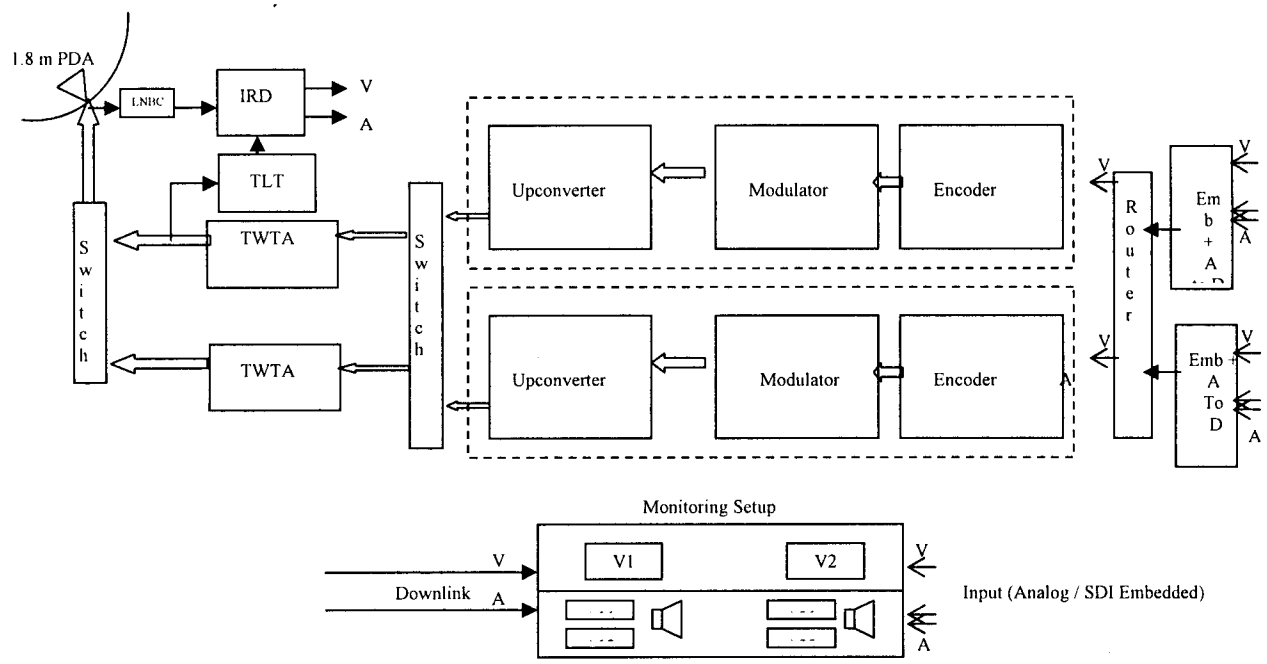

D:/A Insat /Specs/C Band DSNG Flyaway\_400W.ppt

*File*  
30/8/10

*SR*

P. 25/24